

INSTALLATION INSTRUCTIONS

MORRIS CONTOUR/QUANTUM HIGH-RATE SIDE
BAND LIQUID AND NH3 OPENERS



2110 Park Avenue Brandon, Manitoba, Canada R7B 0R9

Website: www.atomjet.com

Email: agriculture@atomjet.com

Phone: 1.204.728.8590

Fax: 1.204.726.5734

Toll Free: 1.800.573.5048

IMPORTANT WARRANTY/GUARANTEE INFORMATION

DO NOT DESTROY

Any claims under the guarantee must be COMPLETED BY OCTOBER 31 IN THE YEAR OF PURCHASE to qualify for a full refund. To satisfy a claim, Atom-Jet Industries must be given the opportunity during the seeding season to rectify the problem or issue, if NOT THE GUARANTEE IS NULL AND VOID. Wear under normal use is not covered by warranty/guarantee.

To activate your warranty registration, scan this QR code using the application on your mobile device and fill out the online form. Upon receipt of the completed form, we will send you a free pair of Atom-Jet work gloves.



WARRANTY IS TO BE COMPLETED BY OCTOBER 31 IN THE YEAR OF PURCHASE. The openers will either be Replaced or Repaired during this period. If you need to return an opener for warranty, please enclose your name, the farm name, address, phone number with area code, dealer purchased from, number of openers purchased, and the date of purchase. Please enclose copy of original invoice. Inclusion of the information will significantly speed up your warranty claim.



Before You Start

Our openers are designed to be compatible with all Morris Contour 1, Contour 2, and Quantum drills. Do not modify your openers to mount on your drill. See the below diagram to see which mounting holes to use on your drill.

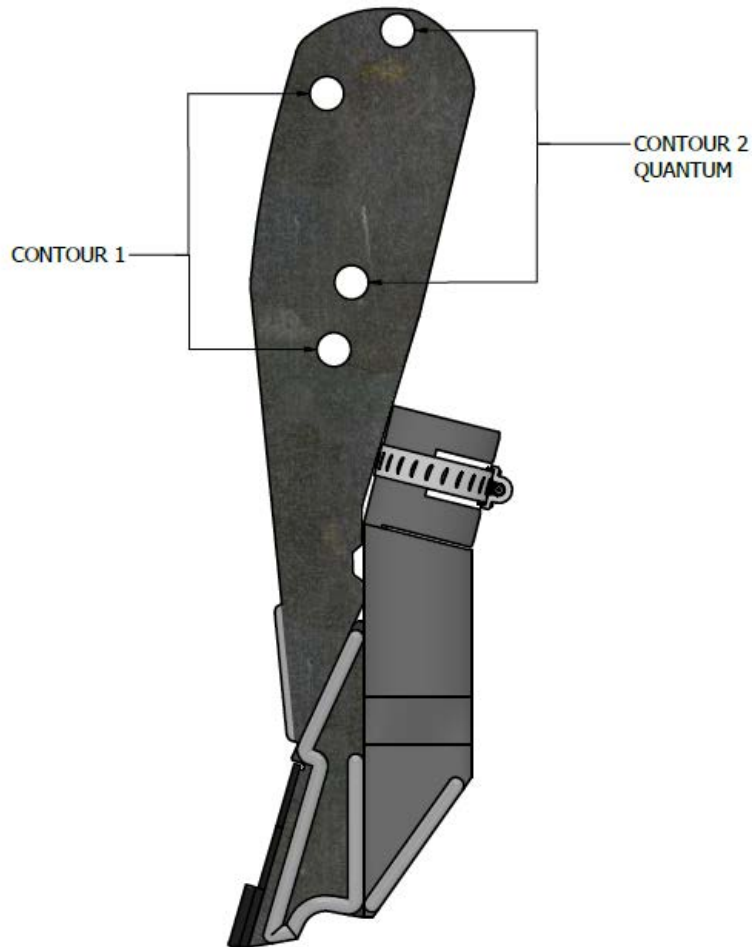

Figure 1: Bolt hole diagram

Note: All diagrams in this instruction set are shown on the Contour 2 shank.

Opener Installation

- 1) Bolt openers to shank using the provided $\frac{1}{2}$ " x $1 \frac{7}{8}$ " bolts and nuts. You may need to use a screwdriver or a pry bar to open the shank to mount the opener. Mount the openers with the seed chute pointed towards the center of the drill (see Figure 3 below).

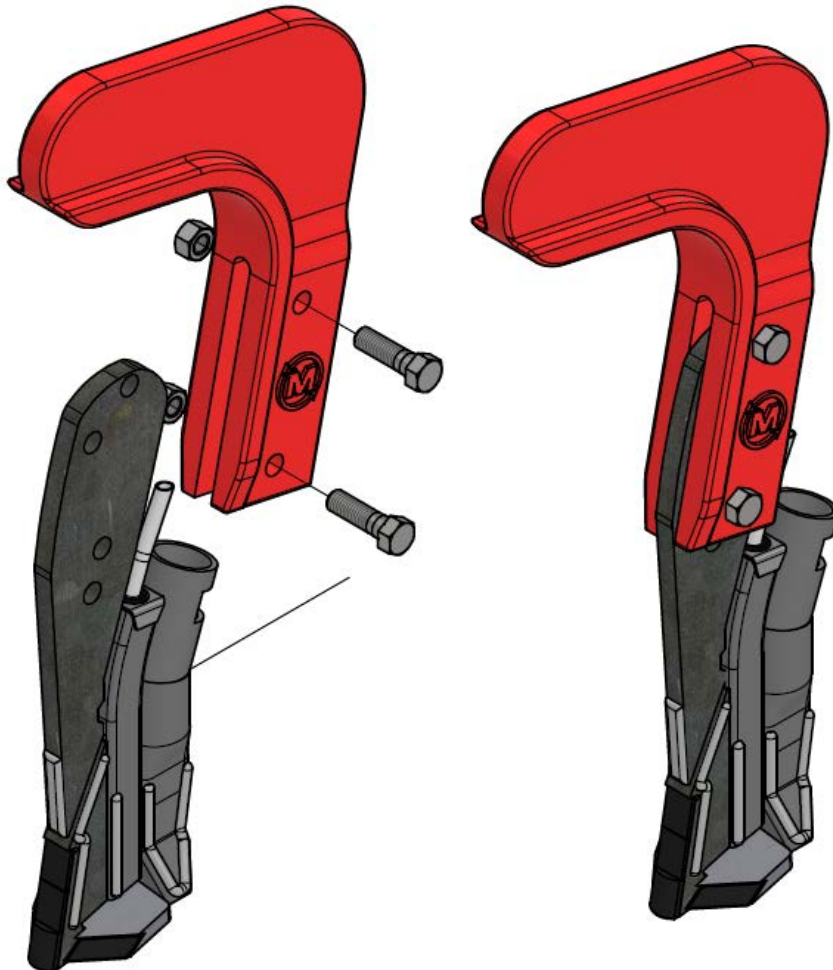

Figure 2: Bolt opener to shank

High-rate side band liquid and NH₃ openers must be installed with the seed chutes oriented to the center of the drill. A left opener will have the seed chute on the left side as seen in Figure 3.

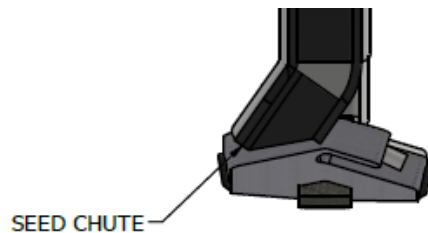

Figure 3: Seed chute on "left" opener

Mounting your openers on the correct side of the drill will reduce the chances of plugging while turning with the drill in the ground. A “left” opener will have the seed chute pointed to the left when viewed from the back. In Figure 4, the arrows represent the direction of the seed chute.

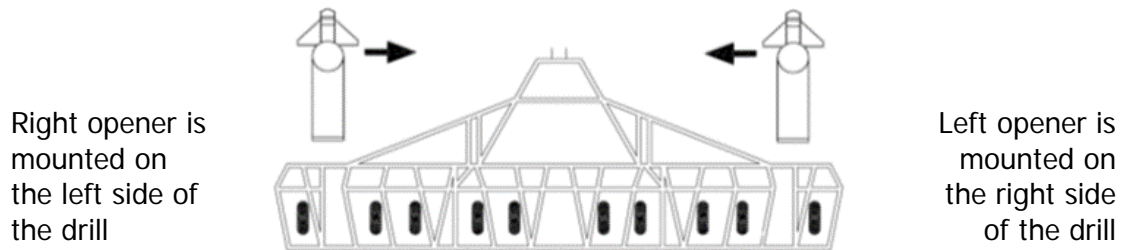

Figure 4: Opener orientation

- 2) Install the seed hose into the opener just past the bend. Secure the hose with the supplied #20 hose clamp.

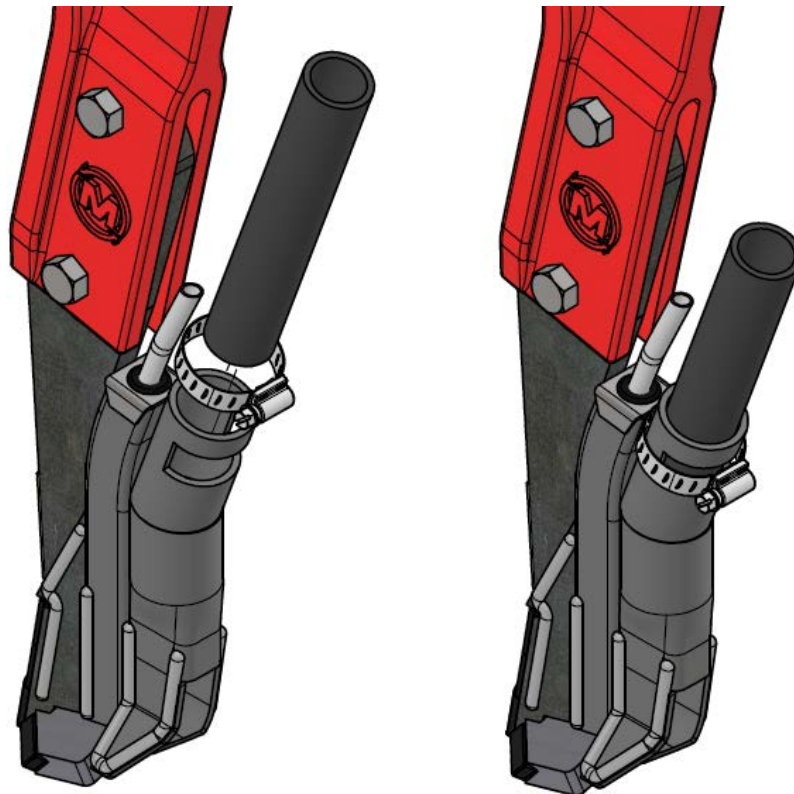

Figure 5: Install seed hose

Our openers are designed to allow hoses of different diameters. Hose bushings will be required for $\frac{3}{4}$ " ID hoses. Short pieces of delivery hose sliced vertically and slipped over the delivery hose make good bushings. If desired, a bushing can be purchased through Atom-Jet: part OP-CB15 TUBE SPACER.

- 3) Install the fertilizer tube on the stainless steel tube. Slide the fertilizer tube over the stainless steel tube and secure with the supplied hose clamp. To prevent dislodging of the line, zip tie the fertilizer hose to the seed hose and drill frame.

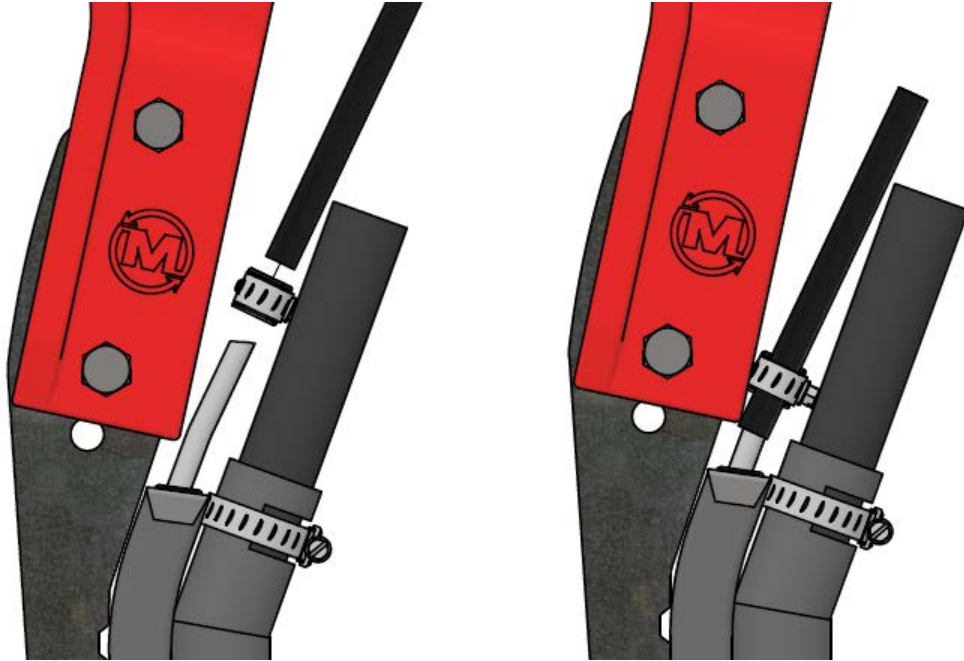

Figure 6: Install fertilizer hose

Opener Maintenance

Atom-Jet openers are designed to be tough, durable, and reliable in all soil conditions. To extend the life of your openers even further, follow these steps:

- 1) Exchange openers from the wheel tracks with other areas of the drill or cultivator.
- 2) Maintain hard surfacing on the openers by building up the areas that were hard surfaced at the factory. Detailed instructions on how to do this are on the back page. Hard surface welding sticks and hard surface wire can be purchased through your local welding supply store.

Hard Surfacing

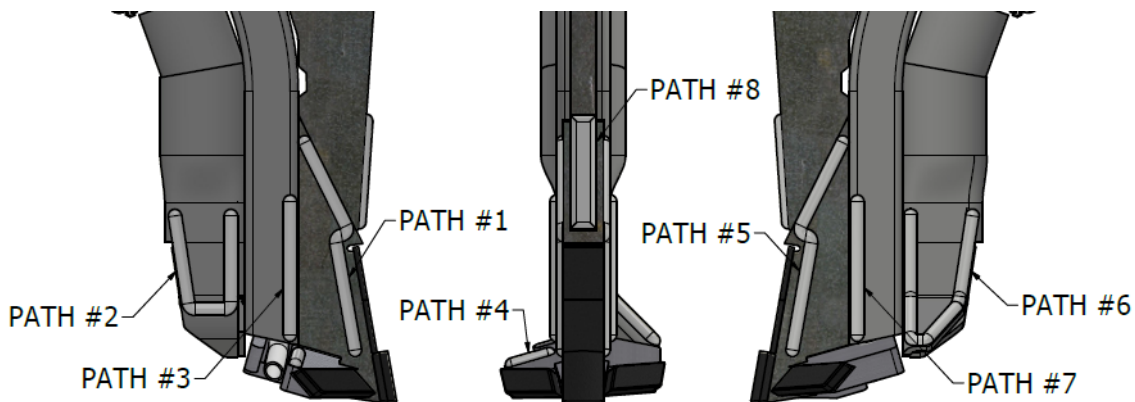

One of the reasons we chose steel to build our openers is the ease with which they can be maintained. The following steps are for re-building the hard surface weld beads:

- 1) Maintain the hard surfacing on the openers by building up the areas we have hard surfaced in the factory. Clean off the openers and work on at least ten openers at a time. The idea is to minimize the heat build-up in the opener, preventing any damage to the carbide.
- 2) Follow these steps:
 - a. Starting $\frac{1}{8}$ " away from the carbide, do PATH #1 on all openers.
 - b. Then, do PATH #2 on the skirting of all openers. It may help to clamp a piece of steel inside the boot plate to give backing to the weld and to act as a heat sink.
 - c. Next, do PATH #3 on the tube shield.
 - d. Hold the opener so the wing is flat. Starting $\frac{1}{8}$ " away from the carbide, do PATH #4 on the wing.
 - e. Turn the openers over and do PATHS #5 to #7 following the same method as the first side.
 - f. Finally, hold the opener so the point faces up. Starting $\frac{1}{8}$ " away from the carbide, do the paths marked #8 on all openers.
- 3) Atom-Jet Industries regularly performs this process for many customers. Call today for a quote at 1-800-573-5048.