

INSTALLATION INSTRUCTIONS

C-SHANK SINGLE SHOOT SPREAD OPENERS



2110 Park Avenue Brandon, Manitoba, Canada R7B 0R9

Website: www.atomjet.com

Email: agriculture@atomjet.com

Phone: 1.204.728.8590

Fax: 1.204.726.5734

Toll Free: 1.800.573.5048

IMPORTANT WARRANTY/GUARANTEE INFORMATION

DO NOT DESTROY

Any claims under the guarantee must be COMPLETED BY OCTOBER 31 IN THE YEAR OF PURCHASE to qualify for a full refund. To satisfy a claim, Atom-Jet Industries must be given the opportunity during the seeding season to rectify the problem or issue, if NOT THE GUARANTEE IS NULL AND VOID. Wear under normal use is not covered by warranty/guarantee.

To activate your warranty registration, scan this QR code using the application on your mobile device and fill out the online form. Upon receipt of the completed form, we will send you a free pair of Atom-Jet work gloves.



WARRANTY IS TO BE COMPLETED BY OCTOBER 31 IN THE YEAR OF PURCHASE. The openers will either be Replaced or Repaired during this period. If you need to return an opener for warranty, please enclose your name, the farm name, address, phone number with area code, dealer purchased from, number of openers purchased, and the date of purchase. Please enclose copy of original invoice. Inclusion of the information will significantly speed up your warranty claim.



Before You Start

The opener is based on a 50° shank angle so shimming may be needed to correctly adjust the opener to the appropriate angle. CHECK YOUR DRILL AND DO NOT ASSUME THE MANUFACTURER'S INFORMATION IS ACCURATE. Atom-Jet reserves the right to refuse warranty if the shank angle is not within tolerances as shown below.

The stainless steel top is designed to adapt to all openers. Until you are sure of your requirements, DO NOT REMOVE any knock out parts.

Following these instructions will ensure the correct angle of the openers, proper placement of seed and fertilizer, and increase the longevity of the opener.

Verifying The Opener Angle Using an Angle Finder

Install a few openers on your drill, at least one for each rank. Use the following procedure to ensure correct installation.

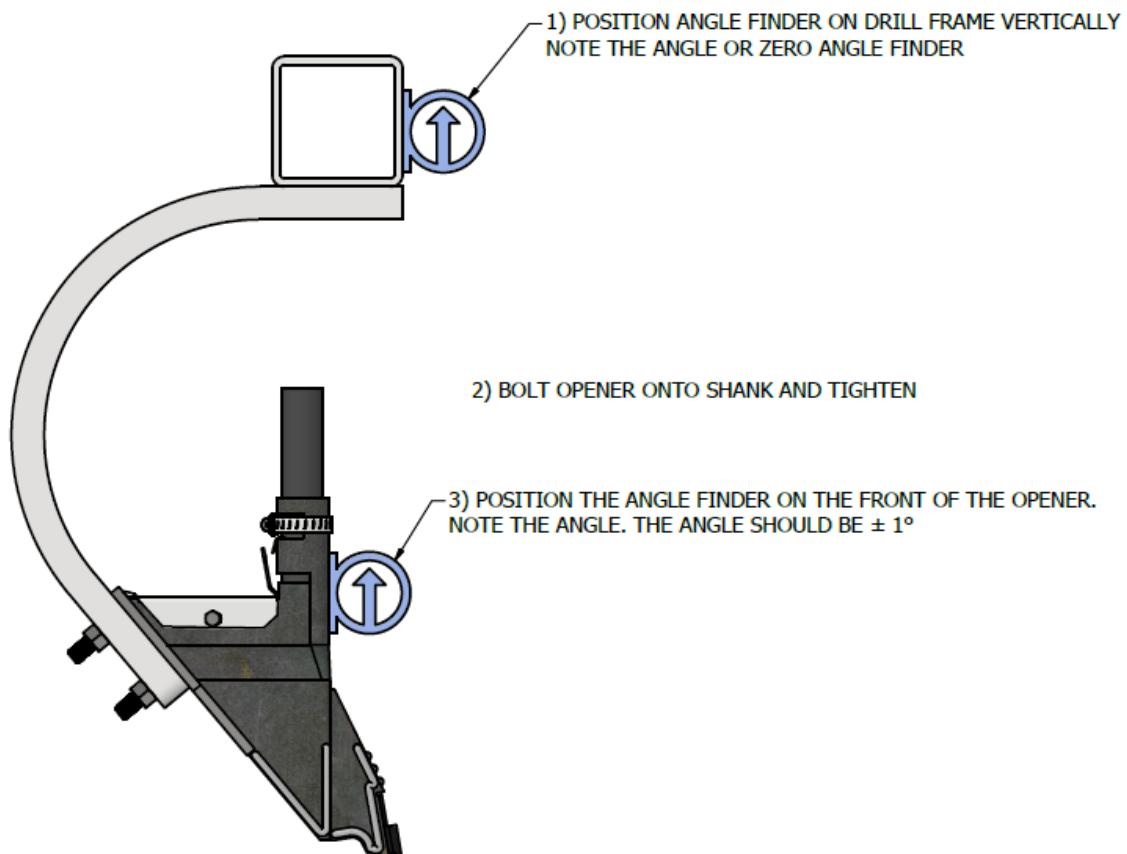

Figure 1: Angle measurement procedure

Install the rest of the openers shimmed as shown above. Sight down the ranks of your drill and adjust openers that appear to be out of position with the properly installed openers. Shims can be purchased from Atom-Jet to correct the opener angle. Figure 2 on the next page shows which shims are needed and their part numbers.

Most John Deere 737 and 1820 drills require a shim (Part # ZT-CZPJ00) on the bottom hole of the opener to set the correct angle. Without the shim, the opener will be set at the incorrect angle (53°-54°).

Shanks that measure 47° should be shimmed with the part shown below (ZT-CZPK00) on the top bolt hole.

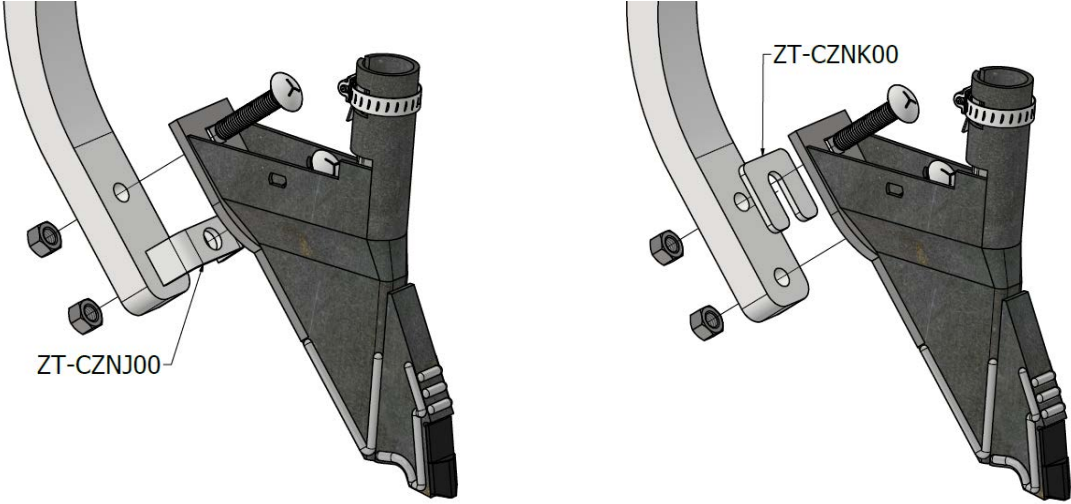

Figure 2: Shims to correct opener angle

Opener Installation

- 1) Bolt openers to shank using the supplied carriage bolts, washers, and nuts, remembering to check the shank angle as described above.

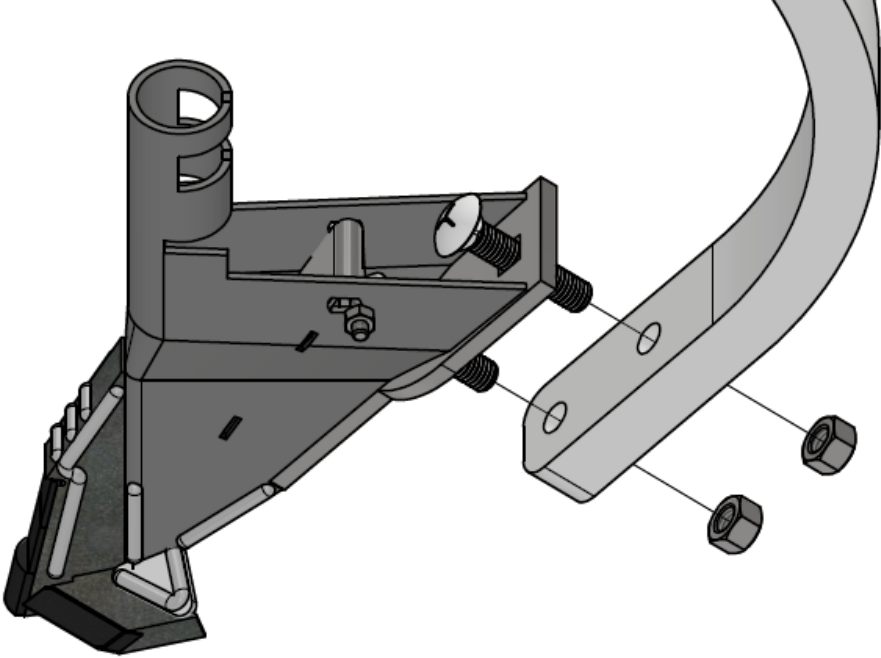

Figure 3: Bolt opener to shank

- 2) Loosely slide the #20 hose clamp over the seed delivery tube and then insert the seed hose into the opener to where the opener narrows.

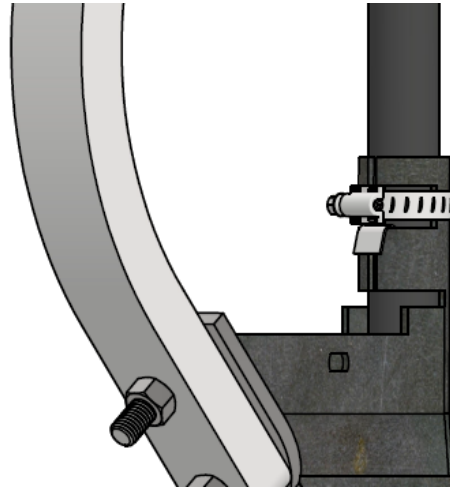

Figure 4: Install seed tube

Openers are designed to allow hoses of different diameters. Hose bushings will be required for $\frac{3}{4}$ " ID hoses. Short pieces of delivery hose sliced vertically and slipped over the delivery hose make good bushings. If desired a bushing can be purchased through Atom-Jet: part OP-CB15 TUBE SPACER.

- 3) Install the opener top with the supplied $2 \frac{1}{2}$ " x $\frac{1}{4}$ " bolt and locknut.

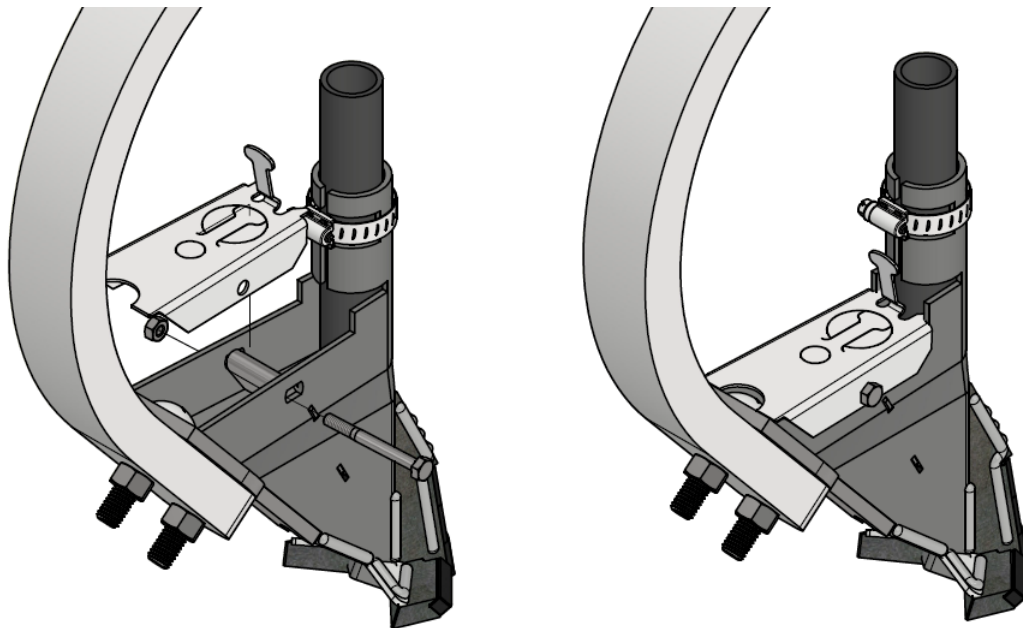

Figure 5: Install opener top

DO NOT REMOVE the knock outs as they are not needed for single shoot spread openers.

Opener Maintenance

Atom Jet openers are designed to be tough, durable, and reliable in all soil conditions. To extend the life of your openers even further, follow these steps:

- 1) Exchange openers from the wheel tracks with other areas of the drill or cultivator.
- 2) Maintain hard surfacing on the openers by building up the areas that were hard surfaced at the factory. Detailed instructions on how to do this are shown below. Hard surface welding sticks and hard surface wire can be purchased through your local welding supply store.
- 3) Carbide protected wings for spread openers can be purchased through Atom-Jet to weld on to replace broken and worn-out wings.

Hard Surfacing

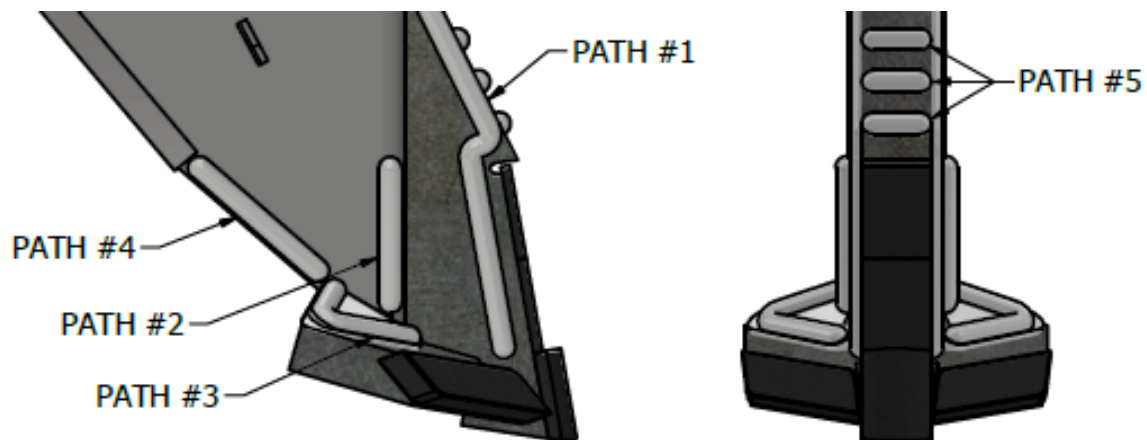

Figure 6: Hard surface paths

One of the reasons we chose steel to build our openers is the ease with which they can be maintained by rebuilding the hard surface welds. Here is the process for rebuilding the welds:

- 1) Clean off the openers and work on at least ten (10) openers at a time. The idea is to minimize the heat build-up in the opener, preventing any damage to the carbide.
- 2) Follow this order:
 - a. First, starting $\frac{1}{8}$ " away from the carbide, do PATH #1 on all openers.
 - b. Then, do PATH #2 on the skirting of all openers. It may help to clamp a piece of steel inside the boot plate to give backing to the weld and to act as a heat sink.
 - c. Now, do PATH #3 on the wing.
 - d. Then, do PATH #4 using the same method as PATH #2.
 - e. Turn the opener over and repeat the same welds using the same order as the first side.
 - f. Finally, starting $\frac{1}{8}$ " away from the carbide, do PATH #5 on all openers.
- 3) Atom-Jet Industries regularly performs this process for many customers. Call today for a quote at 1-800-573-5048.